

### Features:

- Universal AC input / Full range
- Programmable output Voltage (0% ~ 105%)
- Programmable output Current (0% ~ 105%)
- Forced current sharing at parallel operation
- Constant current limit
- Selectable +5V / 0.5A or +9V / 0.3A auxiliary output
- Global control via RS232
- Remote setting multiple PSU via RS232, RS485 & I<sup>2</sup>C
- Power OK signal
- Remote ON / OFF, Remote sense function
- Protection: OVP, OLP, OTP, SCP, Fan failure
- 3 years warranty



MODEL		AE-3000-12	AE-3000-15	AE-3000-24	AE-3000-30	AE-3000-36	AE-3000-48	AE-3000-60	
Output	DC Voltage Range	12V	15V	24V	30V	36V	48V	60V	
	Rated Current	250A	200A	125A	100A	83.5A	62.5A	50A	
	Current Range	0~250A	0~200A	0~125A	0 ~ 100A	0 ~ 83.5A	0 ~ 62.5A	0 ~ 50A	
	Rated Power	3000W	3000W	3000W	3000W	3006W	3000W	3000W	
	Ripple & Noise (Max.)	Note.2 150mVp-p	150mVp-p	200mVp-p	200mVp-p	200mVp-p	200mVp-p	300mVp-p	
	Voltage Adj. Range	±5.0% Typical adjustment by potentiometer. (VR1)							
	Voltage Tolerance	Note.3 ±2.0%							
	Line Regulation	±1.0%							
	Load Regulation	±1.0%							
	Setup, Rise Time	800ms, 50ms at full load							
Hold Up Time (Typ.)	14ms / 230VAC at full load								
Input	Voltage Range	Note.4 90 ~ 264VAC, 127 ~ 370VDC							
	Frequency Range	47 ~ 63Hz (Refer to de-rating curve)							
	Power Factor (Typ.)	0.95 / 230VAC, 0.98 / 115VAC at full load							
	Efficiency (Typ.)	89%	90%	91%	91%	92%	92%	93%	
	AC Current (Typ.)	36A / 115VAC (3000W), 18A / 230VAC (3000W)							
	Inrush Current (Typ.)	60A / 115VAC, 90A / 230VAC							
	Leakage Current	< 2.5mA / 240VAC							
Protection	Over Load	105% rated output power Protection type: Constant current limit							
	Over Voltage	Variable OVP, 120 ± 7% Vout. Refer to VCI VS OVP curve. Protection type: Latch-style (Recovery after reset AC power ON or inhibit)							
	Over Temperature	85 ±5°C detect on heat sink of primary and secondary side Protection type: Auto recovery after temperature goes down							
Function	Auxiliary Power	Selectable +5V / 0.5A or +9V / 0.3A auxiliary output							
	Remote ON / OFF Control	By external switch							
	Power OK Signal	Open drain signal low when PSU turns on, Max. sink current: 20mA, Max. drain voltage: 40V.							
	Output Voltage Trim	Adjustment of output voltage is between 0 ~ 105% of rated output							
	Output Current Trim	Adjustment of output current is between 0 ~ 105% of rated output							
	Parallel (Current Sharing)	Note.5	Please refer to page 5						
Environment	Working Temp.	-25 ~ +60°C (Refer to de-rating curve)							
	Working Humidity	20 ~ 90% RH non-condensing							
	Storage Temp. & Humidity	-40 ~ +85°C, 10 ~ 95% RH							
	Temp. Coefficient	±0.02% / °C (0 ~ 50°C)							
	Vibration	10 ~ 500Hz, 2G 10min. / 1cycle, period for 60min. each along X, Y, Z axes Compliance to IEC 68-2-6, IEC 68-2-64							
Safety & EMC	Safety Standards	Certified UL 60950-1; EN 60950-1							
	Withstand Voltage	Note.7	I/P-O/P: 3KVAC (4242VDC), I/P-FG: 1.5KVAC (2121VDC), O/P-FG: 0.5KVAC (707VDC)						
	Isolation Resistance	I/P-O/P, I/P-FG, O/P-FG: 100M Ohms / 500VDC							
	EMI Conduction & Radiation	Certified EN 55022; EN 61204-3; EN 61000-6-3							
	Harmonic Current	Certified EN 61000-3-2; EN 61000-3-3							
	EMS Immunity	Note.6	Certified EN 55024; EN 61204-3; EN 61000-6-1; IEC 61000-4-2, 3, 4, 5, 6, 8, 11						
Others	Cooling	Load and temperature control fan							
	Dimension (WxHxD)	366x127x127mm							
	Packing	5.25kg; 4pcs / 21kg / 1.86CUFT							
Note	<ol style="list-style-type: none"> <li>1. All parameters NOT specially mentioned are measured at 230VAC input, rated load and 25°C of ambient temperature.</li> <li>2. Ripple &amp; noise are measured at 20MHz of bandwidth by using a 12" twisted pair-wire terminated with a 0.1uF &amp; 47uF parallel capacitor.</li> <li>3. Tolerance: includes setup time tolerance, line regulation and load regulation.</li> <li>4. De-rating may apply in low input voltage. Please check the de-rating curve for more details.</li> <li>5. In parallel connection only one unit will operate if the total output load is less than 5% of the rated power.</li> <li>6. The power supply is considered a component which will be installed into a final equipment. The final equipment must be re-confirmed that it still meets EMC directives.</li> <li>7. This test is done without enclosure.</li> </ol>								

### Mechanical Drawings:

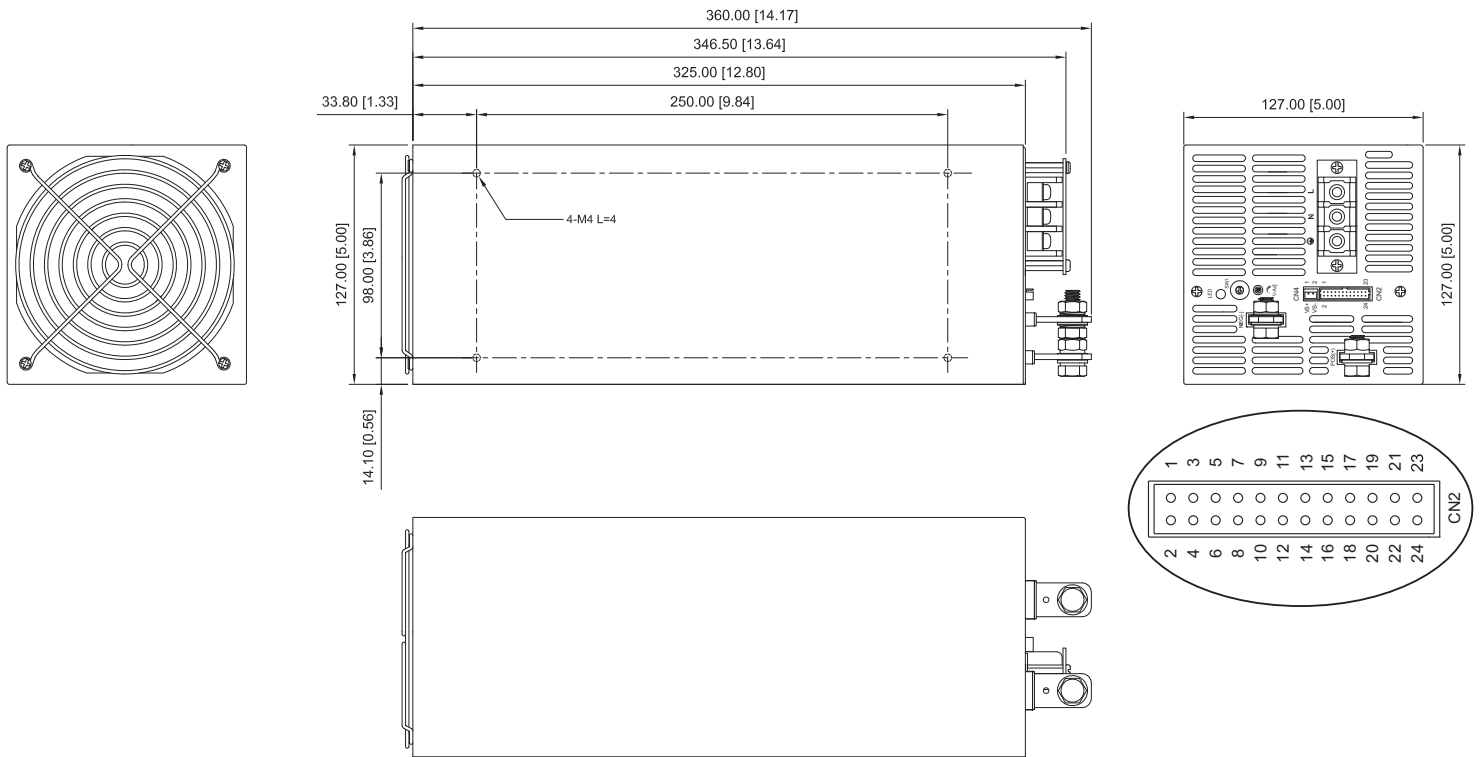

### AC Input Terminal Pin No. Assignment

Pin No.	Assignment
1	ACL
2	ACN
3	⏏

CN4	1	VS+
	2	VS-

### Control pin number assignment (CN2): JST S24B-PHDSS or equivalent

Pin No.	Assignment	Pin No.	Assignment	Pin No.	Assignment	Mating Housing / Contact	
1	VS+	9	EN-	17	AUX	JST PHDR-24VS or equivalent	JST SPHD-002T-P0.5 or equivalent
2	VO+	10	GND	18	GND		
3	VS-	11	EN+	19	SCL		
4	VO-	12	AUX	20	SDA		
5	POK	13	ACI	21	AUX		
6	GND	14	GND	22	GND		
7	PAR	15	VCI	23	NC.		
8	VSET	16	GND	24	NC.		

### CN2 Function Description:

Pin No.	Function	Description	Pin No.	Function	Description
1	VS+	Positive output voltage	13	ACI	I Program
2	VO+	Remote sense (+)	14	GND	Ground
3	VS-	Remote sense (-)	15	VCI	V Program
4	VO-	Negative output voltage	16	GND	Ground
5	POK	Power OK	17	AUX	+5V / 0.5A or +9V / 0.3A Auxiliary power
6	GND	Ground	18	GND	Ground
7	PAR	Parallel operation current share	19	SCL	Serial Clock used in the I <sup>2</sup> C interface
8	VSET	Aux output setting	20	SDA	Serial Data used in the I <sup>2</sup> C interface
9	EN-	Inhibit ON/OFF (-)	21	AUX	+5V / 0.5A or +9V / 0.3A Auxiliary power
10	GND	Ground	22	GND	Ground
11	EN+	Inhibit ON/OFF (+)	23	NC.	For RS232 Transmission function
12	AUX	+5V / 0.5A or +9V / 0.3A Auxiliary power	24	NC.	For RS232 Receiver function

### LED Status:

LED	LED Signal	Status
Solid(Green)		Power OK (Local mode)
Solid(Orange)		Power OK (Remote mode)
Slow Blink(Green)		Power Standby
Fast Blink(Red)		Over Voltage Protection ( OVP )
Solid(Red)		Over Load Protection ( OLP )
Slow Blink(Red)		Over Temperature Protection ( OTP )
Intermittent Blink(Red)		Fan Failure
Interface Blink(Red)		Power Failure

\*Local mode : Use ACI/VCI control output current and voltage.  
Remote mode : Use RS-232 or I<sup>2</sup>C command control output current and voltage.

### De-rating Curve:

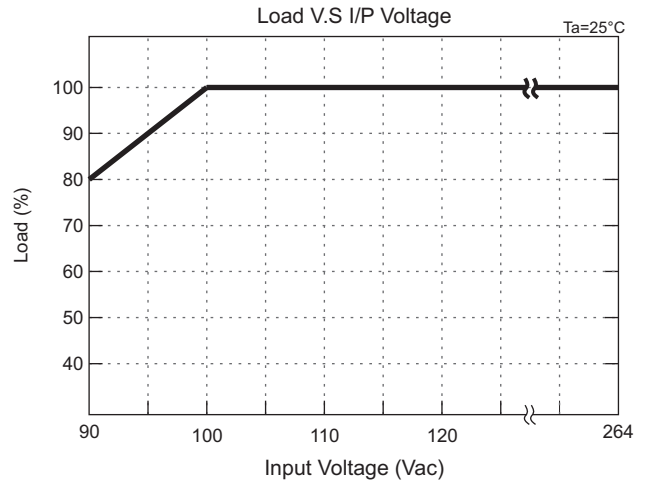
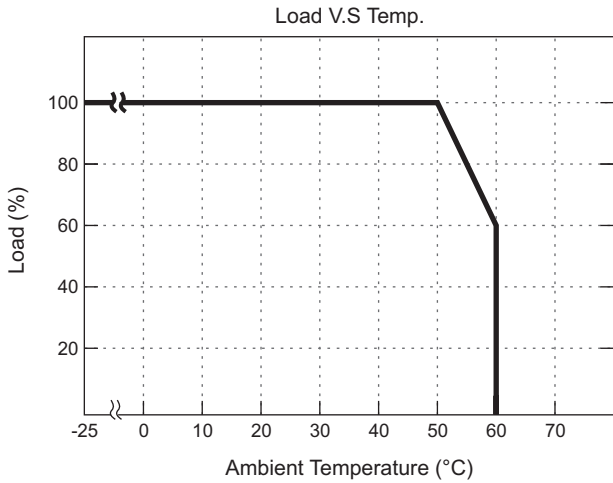

### CMD VS Output Curve:

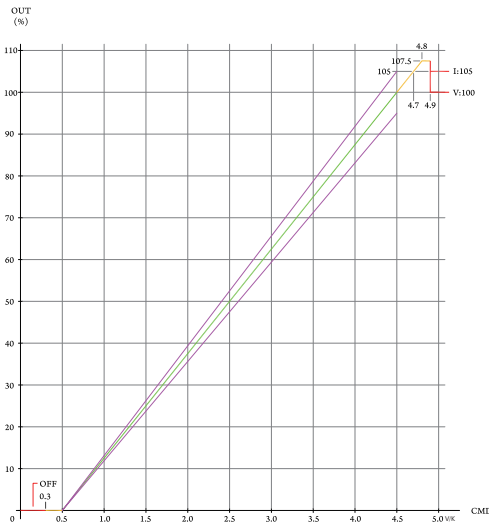

### VCI VS OVP Curve:

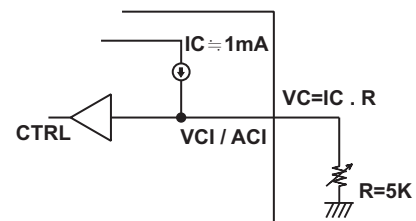
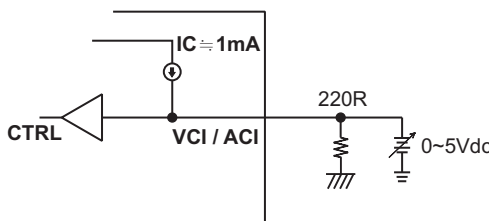
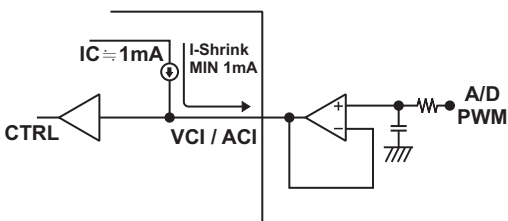
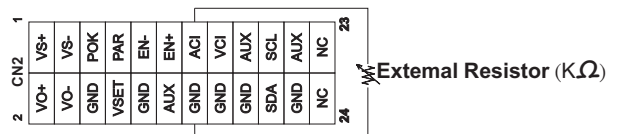
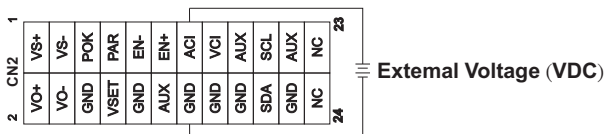
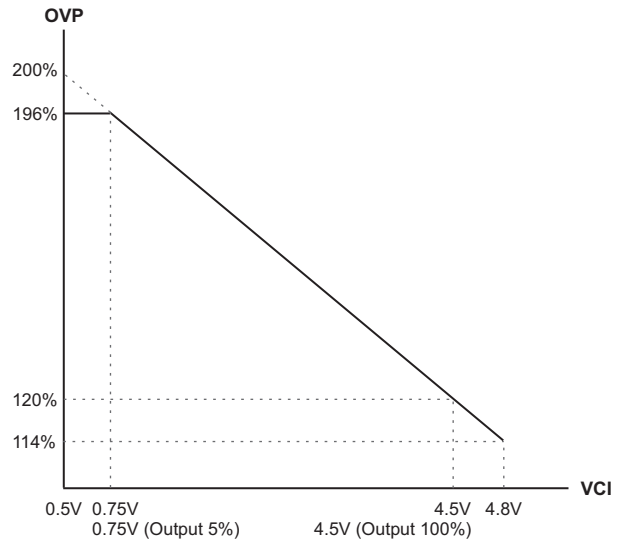

### Remote ON/OFF:

(A) Default Setting

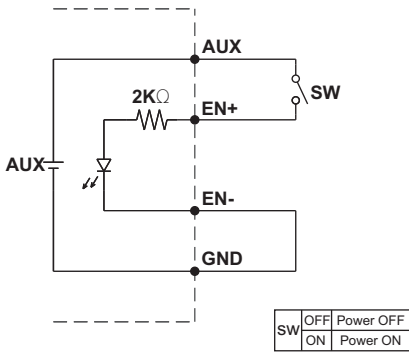

(A) Using internal 5V auxiliary source

(B)

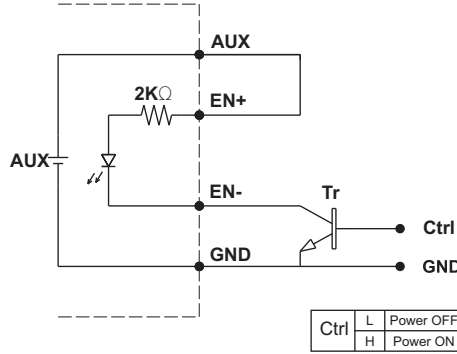

(B) ON / OFF Control by NPN transistor

(C)

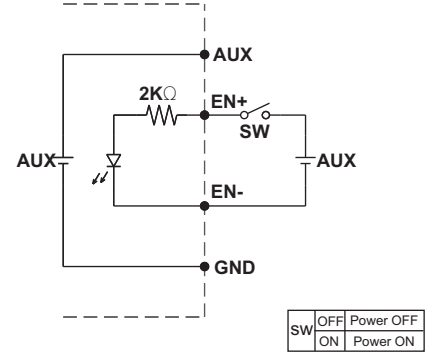

(C) Using external voltage source

### Power OK Signal:

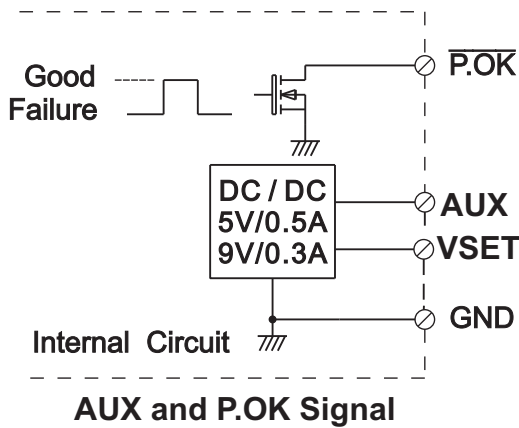

\*Place an additional capacitor to have a better performance of auxiliary power operation.

\*The grounding of "AUX" power should be connected to "GND" port. If "V-" is connected as Grounding, make sure to short the GND and V- ports.

VSET	Open	5V	(Default Setting)
	Short To GND	9V	

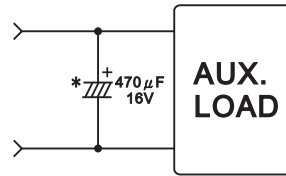

1. Remote Sense

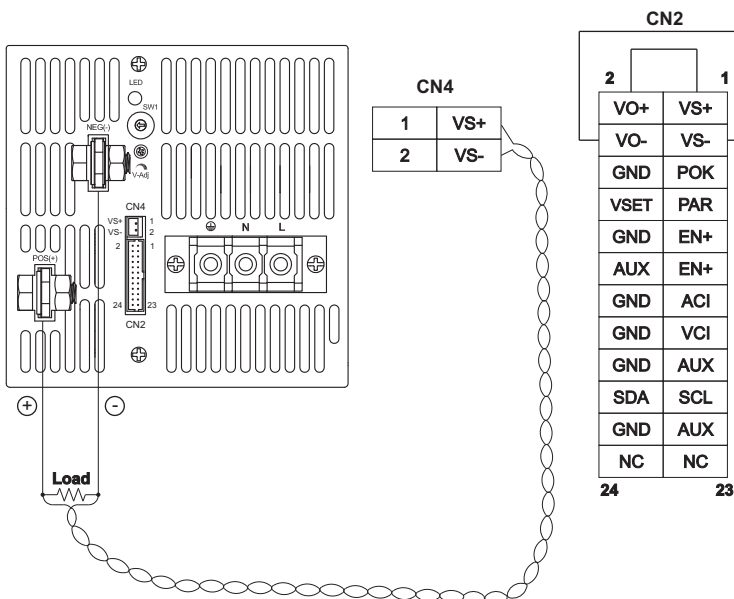

2. Local Sense (Default setting)

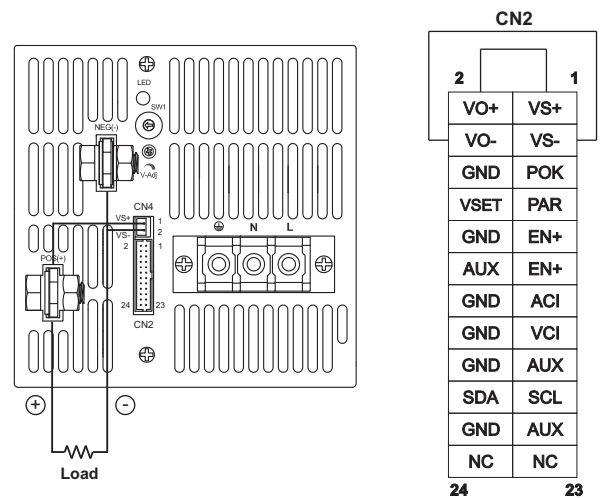

### 3. Current Sharing with Remote Sensing

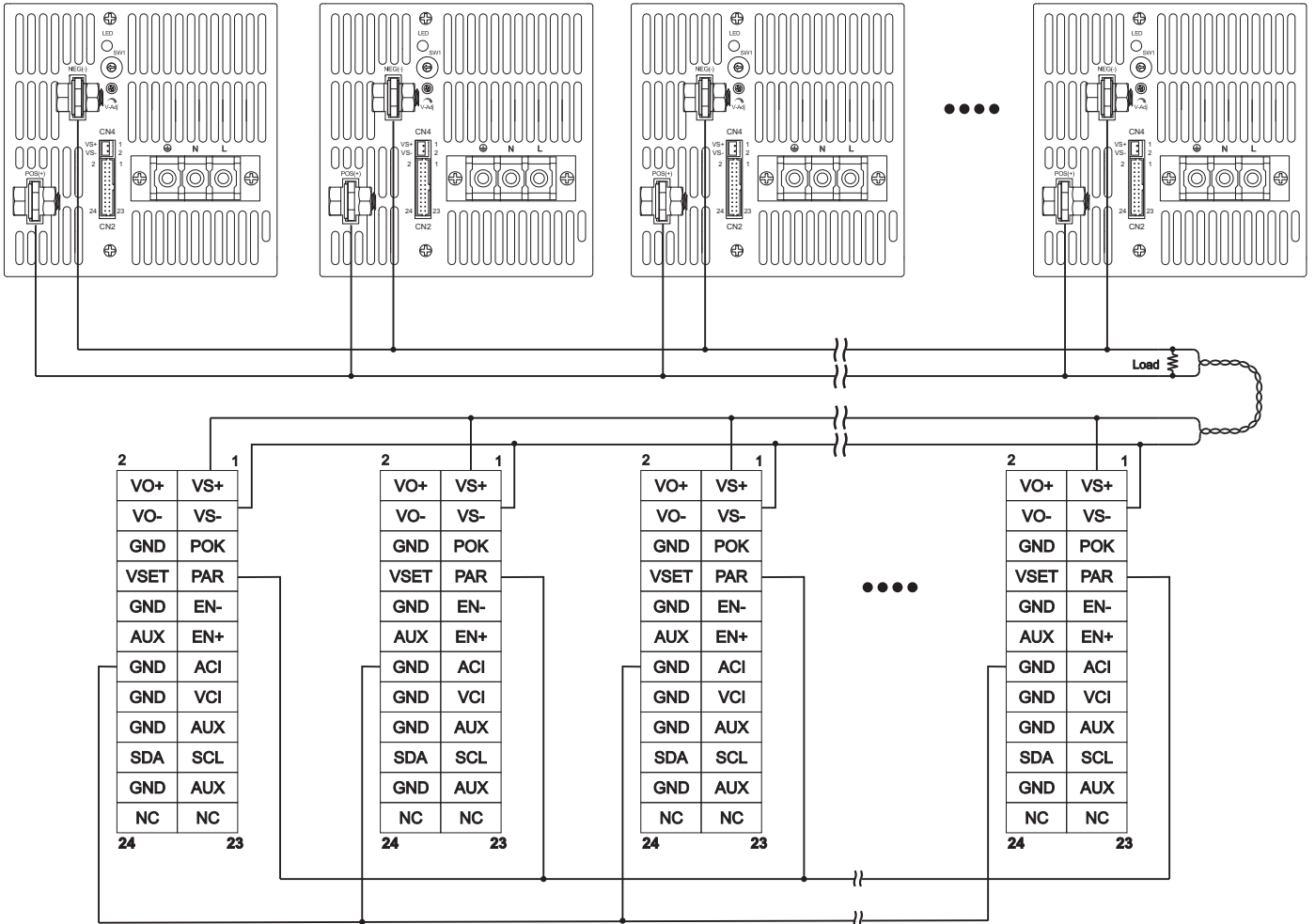

### 4. Current Sharing with Local Sensing

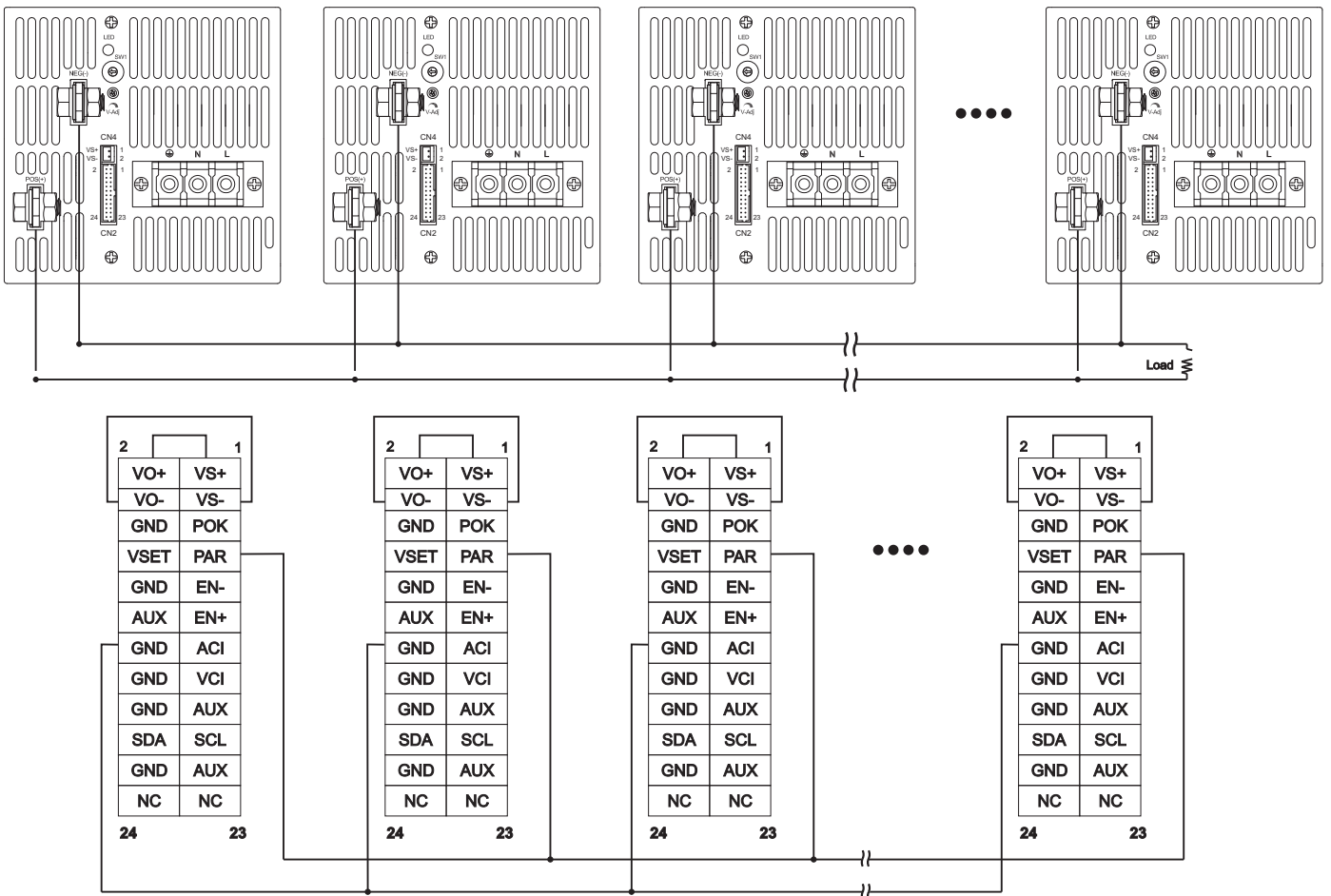

### Installation Instruction:

#### 1. Mounting Directions

1-1 Recommended standard mounting methods:

(a)

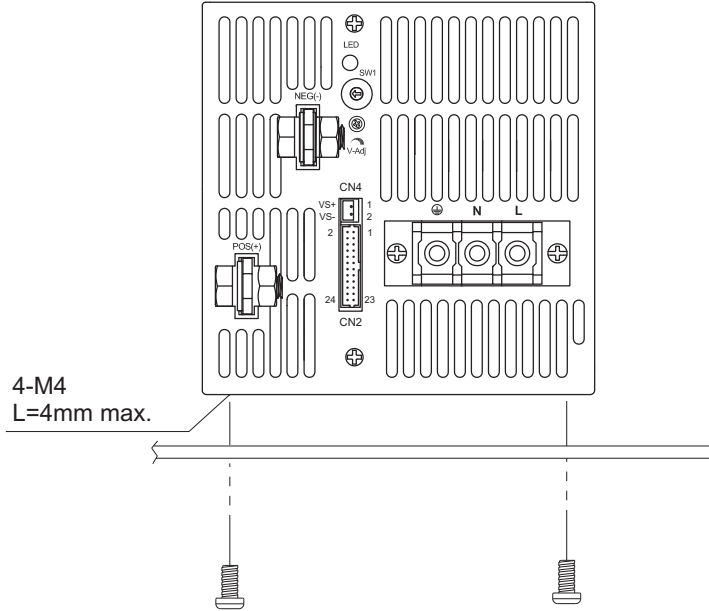

#### 2. Mounting Method

2-1 There are ventilating holes on the front and back side panels, do not obstruct; allow 50mm at least for air flow.

2-2 The Maximum allowable penetration of screw is 4mm. Incomplete threading should not be penetrated.

2-3 Recommended the torque of mounting screw:  
M4 screw: 1.27N · m (13.0kgf · cm)

